

400 Series Tooling Requirements

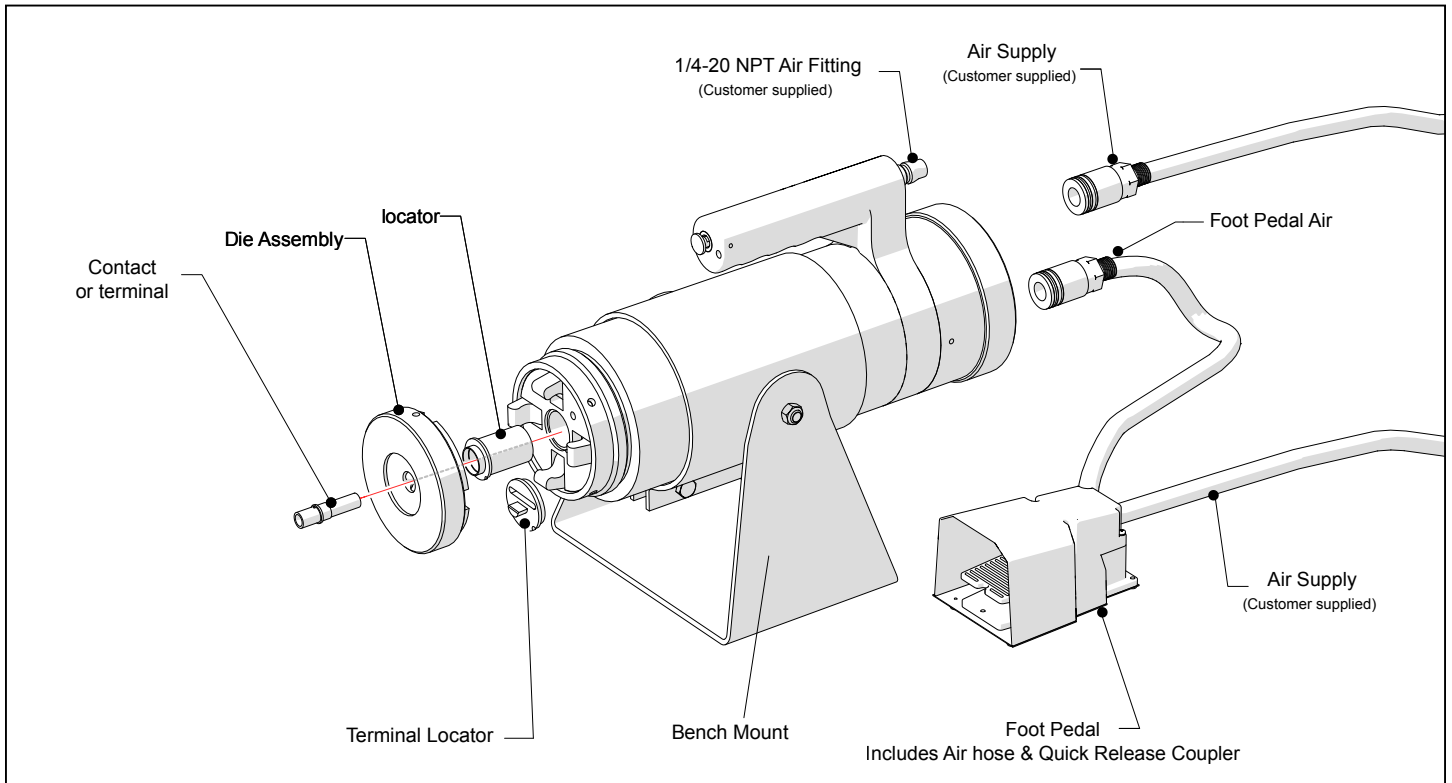

400-BHD, 400-B-1

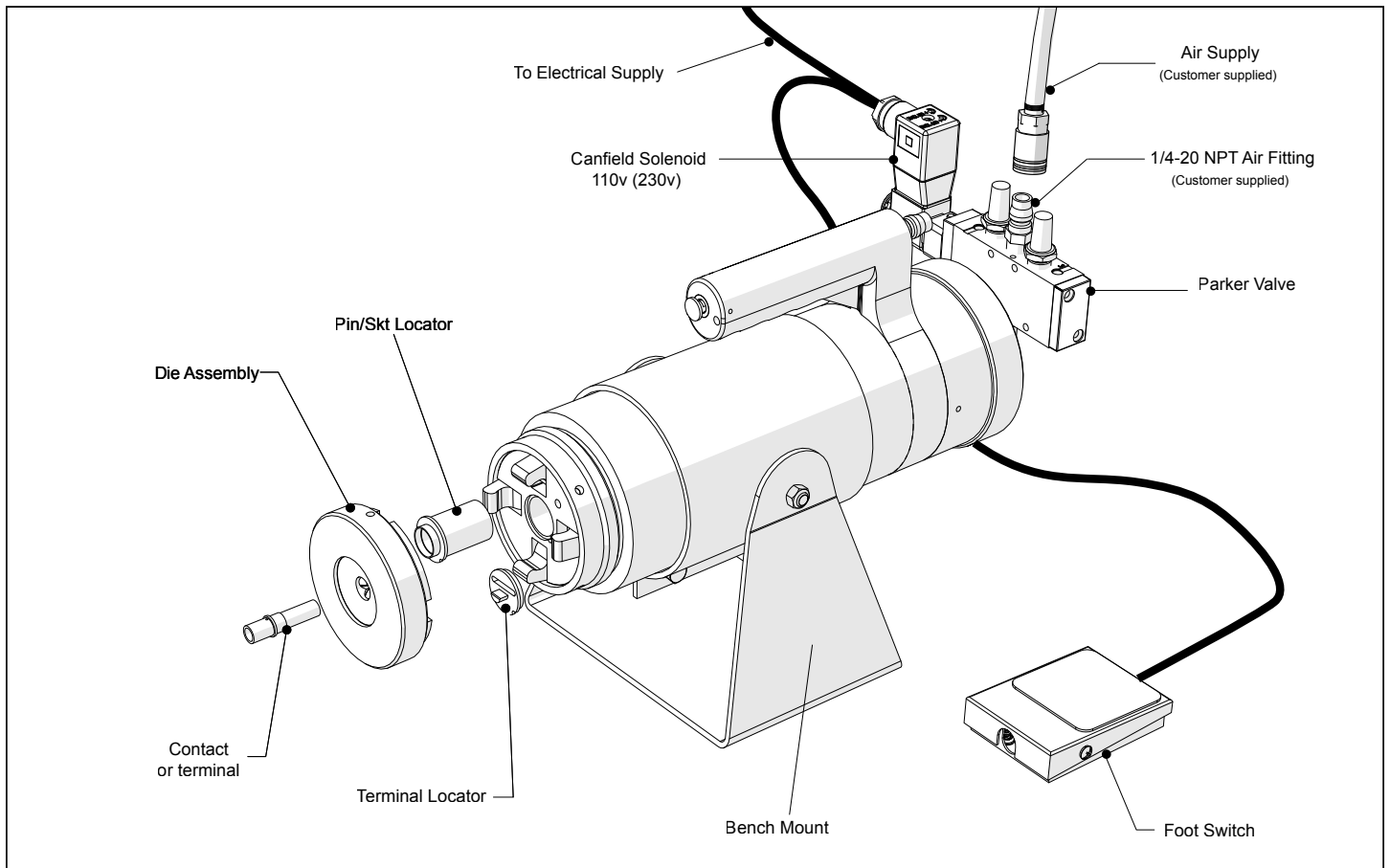

400-BEC, 400-B-1EC

400-BHD Parts List

Key	Part Number	Description	Qty
-	400-BM	Bench mount (see 1st page).....	1
1	400-1H	Handle.....	1
2	6227-12	O-ring.....	1
3	6227-28	O-ring.....	1
4	400-Trigger	Handle Trigger Assembly	1
5	400-1	Body.....	1
6	400-2A	Piston.....	1
7	400-2B	Piston Rod	1
8	6227-42	Piston O-ring.....	1
9	400-27A	Cycling Valve Assembly	1
10	400-32	Return Spring.....	1
11	400-5	Piston Stop	1
12	3000-354	Retaining ring.....	1
13	8-32 x 1/2 FHSCS	Flat head screws - 400-18 to 400-1	4
14	400-18	Housing.....	1
15	10-32 Half Dog x 5/16 FHSCS	Flat head screws - 400-18 to 400-11	4
16	400-TOG	Toggle Assembly.....	1
17	400-11	Retainer.....	1
18	6230-11	O-ring.....	1
19	400-26	Cover Nut.....	1
20	400-30	Booster Body	1
21	1/4*20 x 1-1/2 FHSCS	Flat head screws - Booster to Handle	4
22	400-27A	Cycling Valve Assembly	1
23	400-31	Rear piston rod	1
24	400-2A	Piston.....	1
25	6227-42	Piston O-ring.....	1
26	6230-17	Rear cover O-ring	1
27	400-29	Rear Cover	1
28	1/4-18 x 29/64" NPT Pipe plug	Pipe plug for 400-29 Cover.....	1

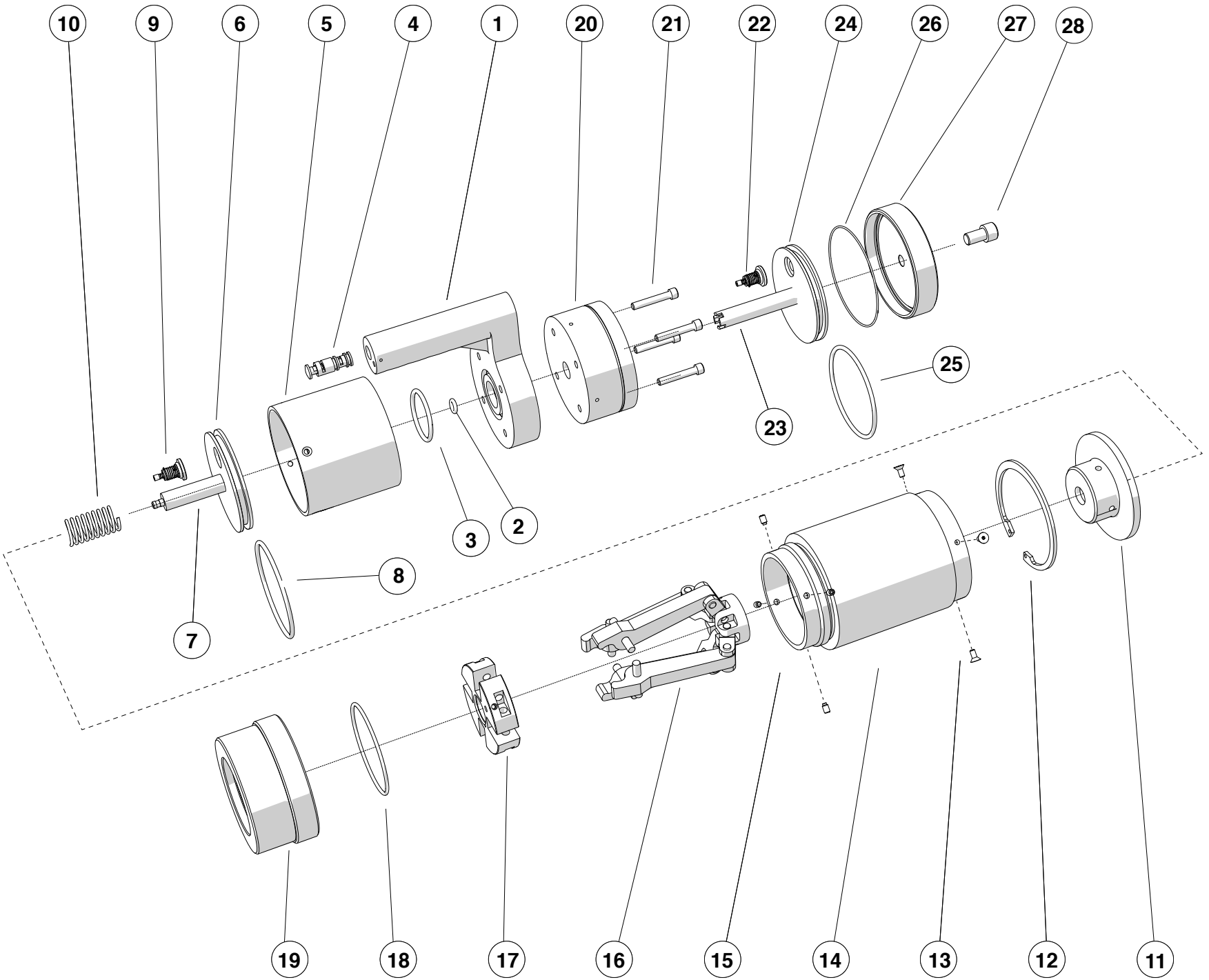

400-BHD

400 Toggle Illustration

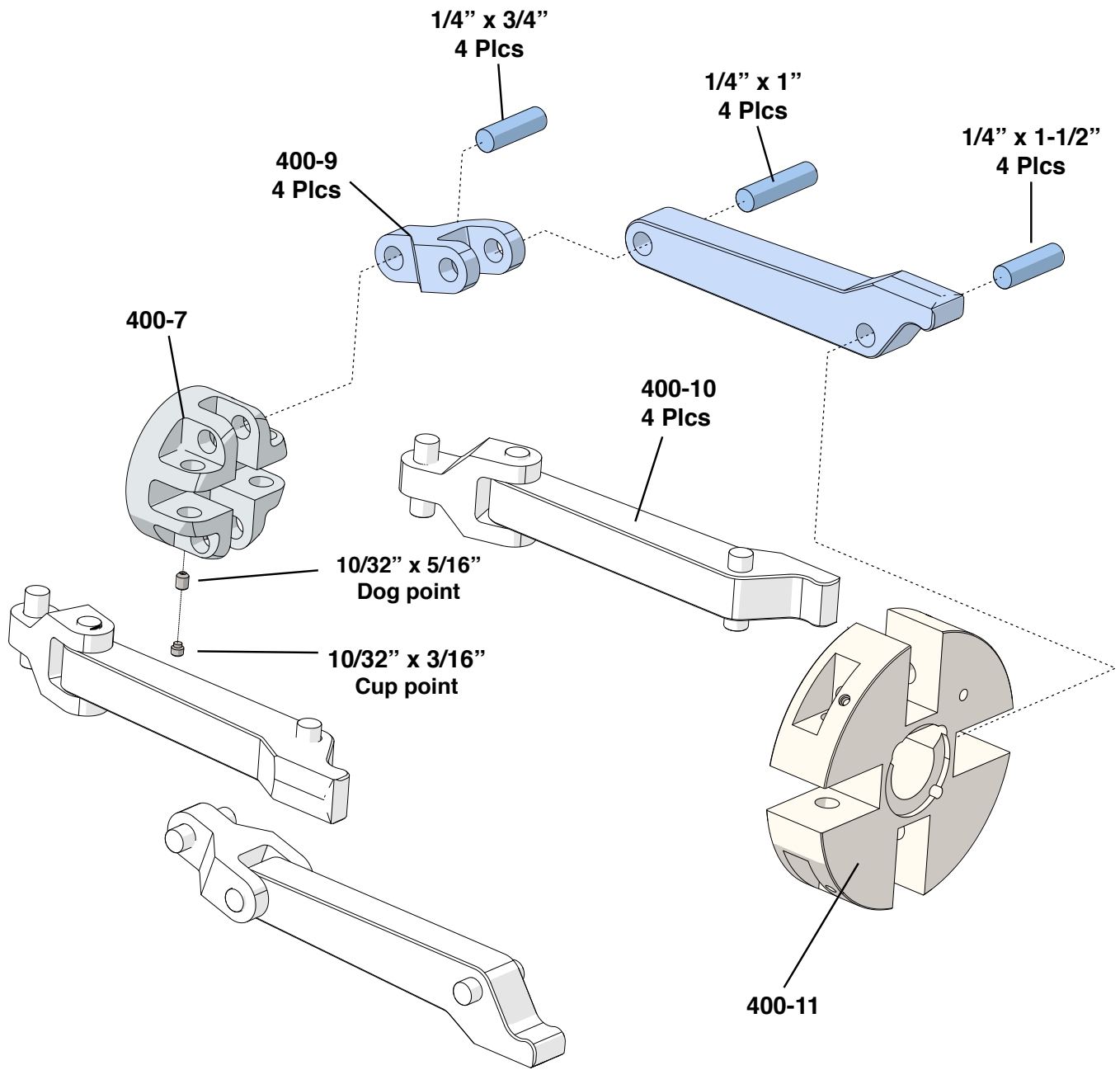

400 Piston Assembly

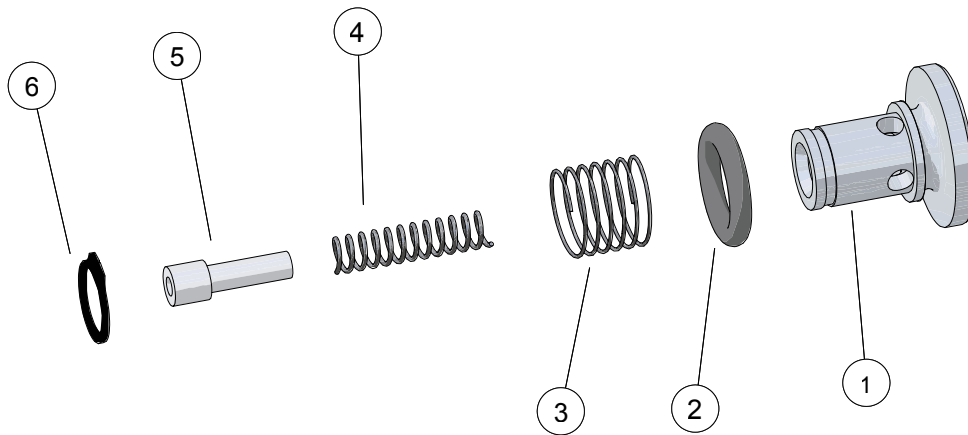
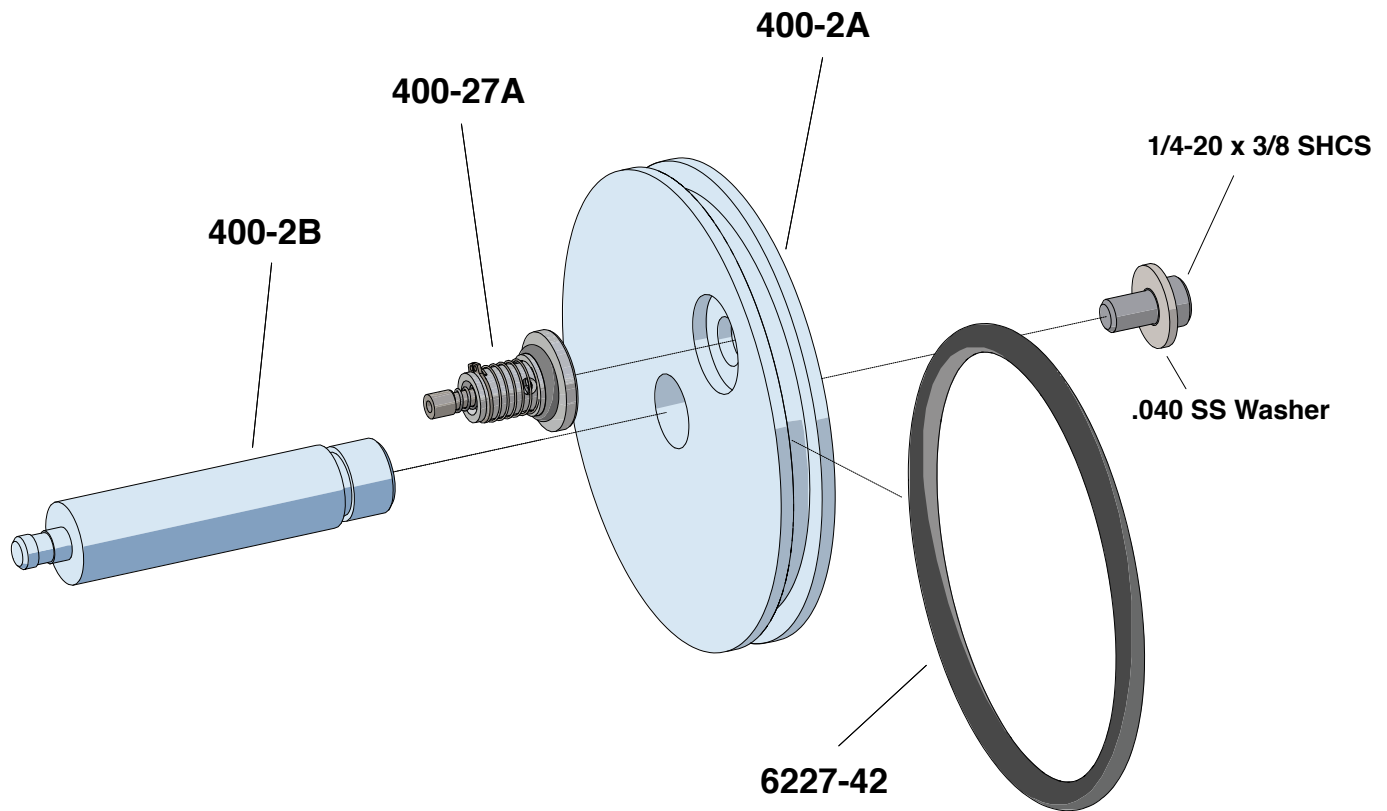

400-27A Cycling Valve Assembly

Description	BOM ID	Qty
71100-37	6	1
6227-08	2	1

Description	BOM ID	Qty
400-28	5	1
400-275	3	1

Description	BOM ID	Qty
400-27	1	1
156C	4	1

400 Crimping Die

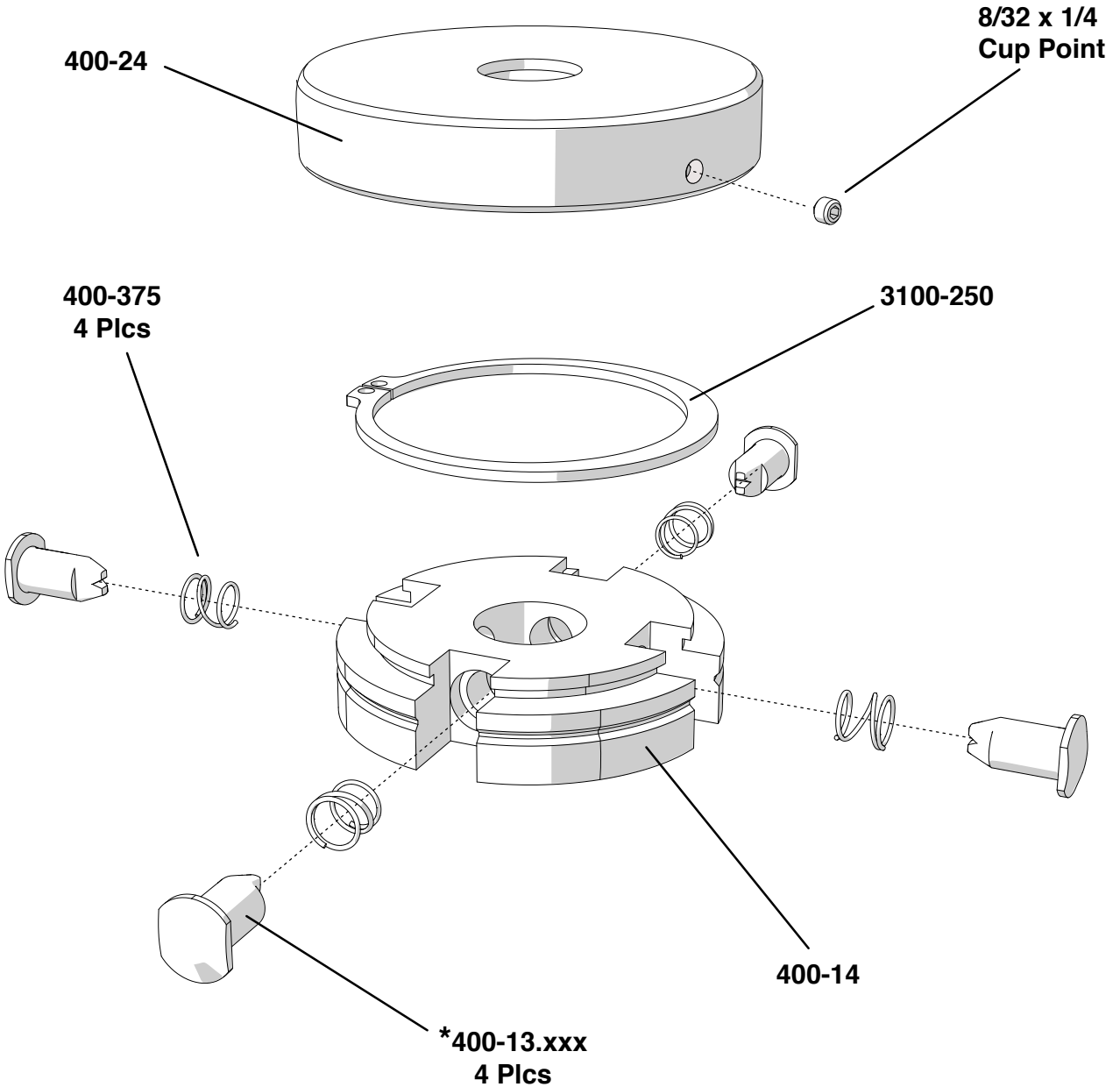

*** NOTE:** Die indentors are determined by application.
'xxx' refers to the die closure (proportional to crimp height).

Consult with Pico to determine the correct parts