

400 Series Tooling Requirements

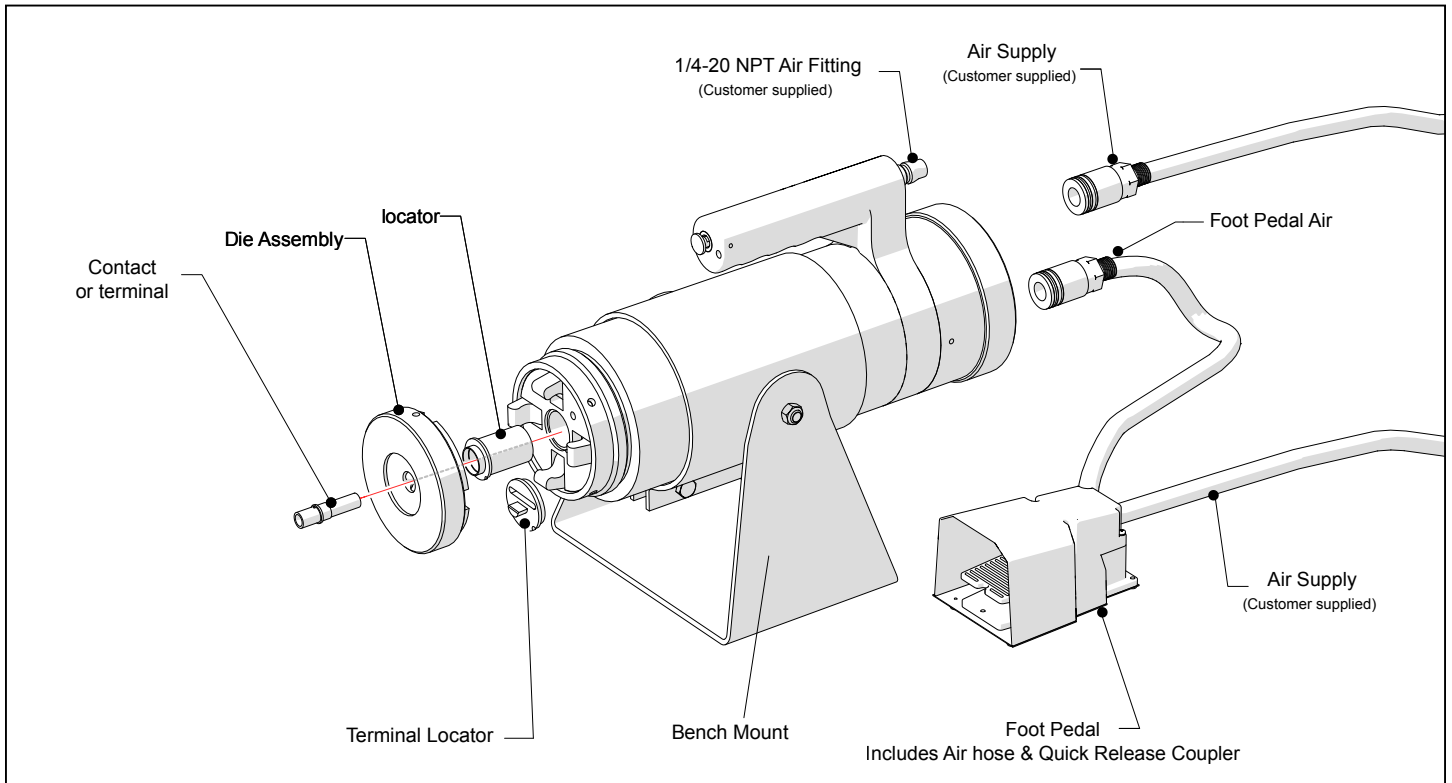

400-BHD, 400-B-1

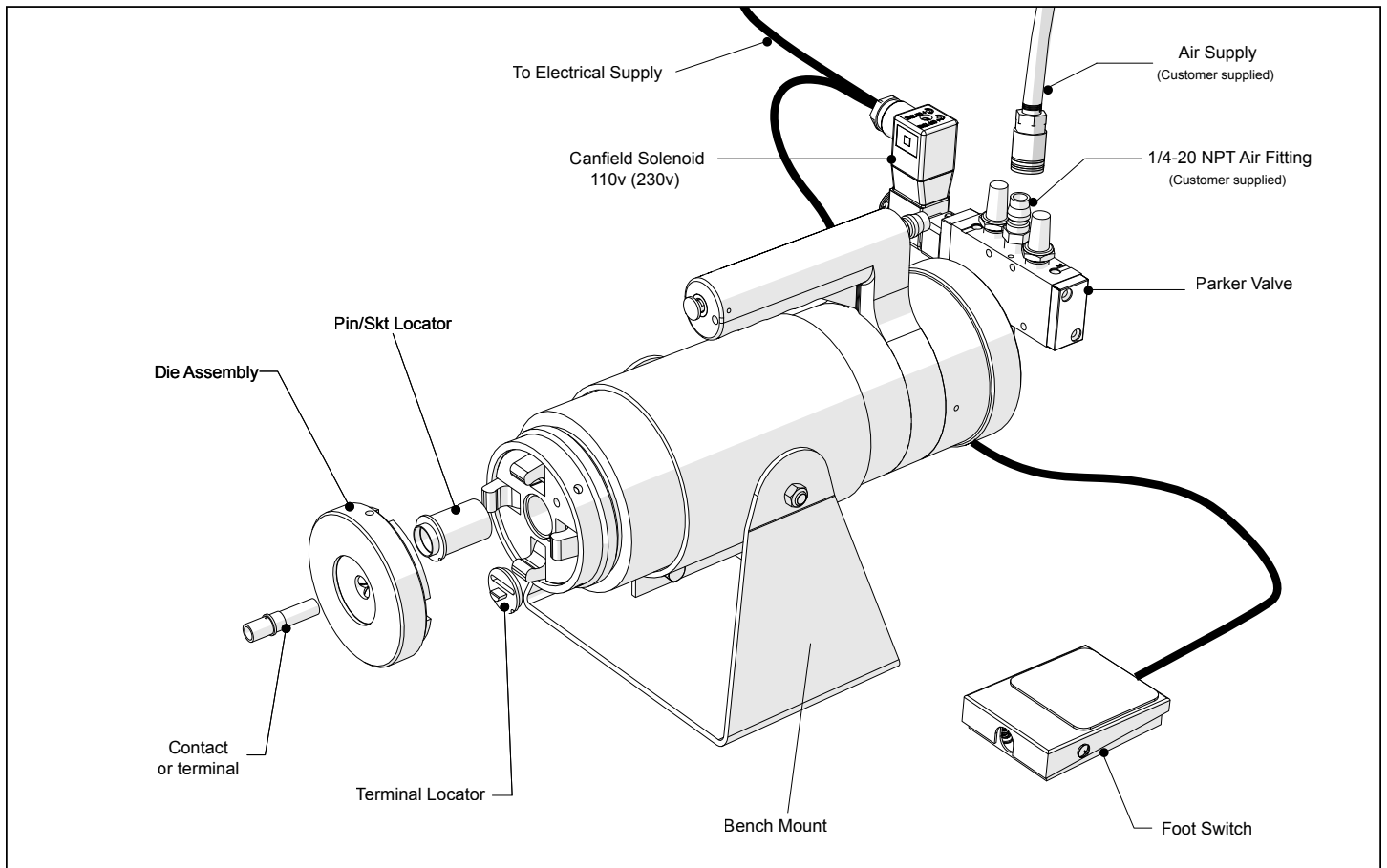

400-BEC, 400-B-1EC

400-BEC Parts List

Key	Part Number	Description	Qty
-	400-BM	Bench mount (see 1st page).....	1
1	400-1	Body.....	1
2	6227-28	O-ring.....	1
3	1187A2	Plastic Handle with screws	1
4	400-1H-EC	Handle Cylinder	1
5	6227-12	O-ring.....	1
6	400-30	Booster Body.....	1
7	1/4*20 x 1-1/2 FHSCS	Flat head screws - Booster to Handle	4
8	400-31	Rear piston rod	1
9	6227-42	Piston O-ring.....	1
10	400-2A	Piston.....	1
11	6230-17	Rear cover O-ring	1
12	400-29	Rear Cover	1
13	1/4-18 x 29/64" NPT Pipe plug	Pipe plug for 400-29 Cover.....	1
14	EC-10	Valve, Solenoid & Foot Switch	1
15	1/4-20 x 3/8 SHCS	Piston Socket head screws	1
16	.040 SS Washer	Stainless Steel Washer	1
17	6227-42	Piston O-ring.....	1
18	400-2A	Piston.....	1
19	400-2B	Piston Rod	1
20	400-32	Return Spring.....	1
21	400-5	Piston Stop	1
22	3000-354	Retaining ring.....	1
23	8-32 x 1/2 FHSCS	Flat head screws - 400-18 to 400-1	4
24	400-18	Housing.....	1
25	10-32 Half Dog x 5/16 FHSCS	Flat head screws - 400-18 to 400-TOG.....	4
26	400-TOG	Toggle Assembly	1
27	6230-11	O-ring.....	1
28	400-26	Cover Nut.....	1

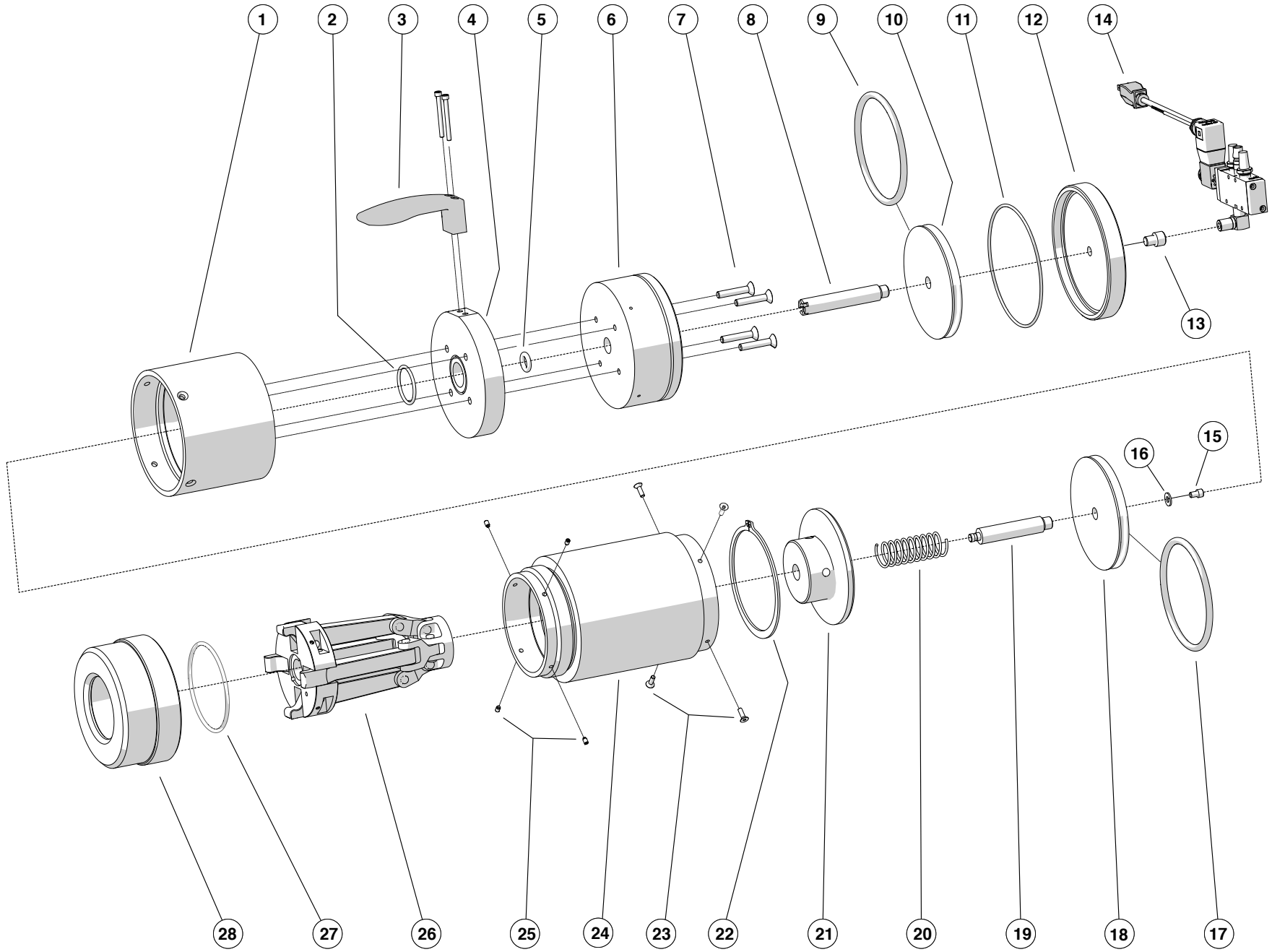

400-B EC Illustration

400 Toggle Illustration

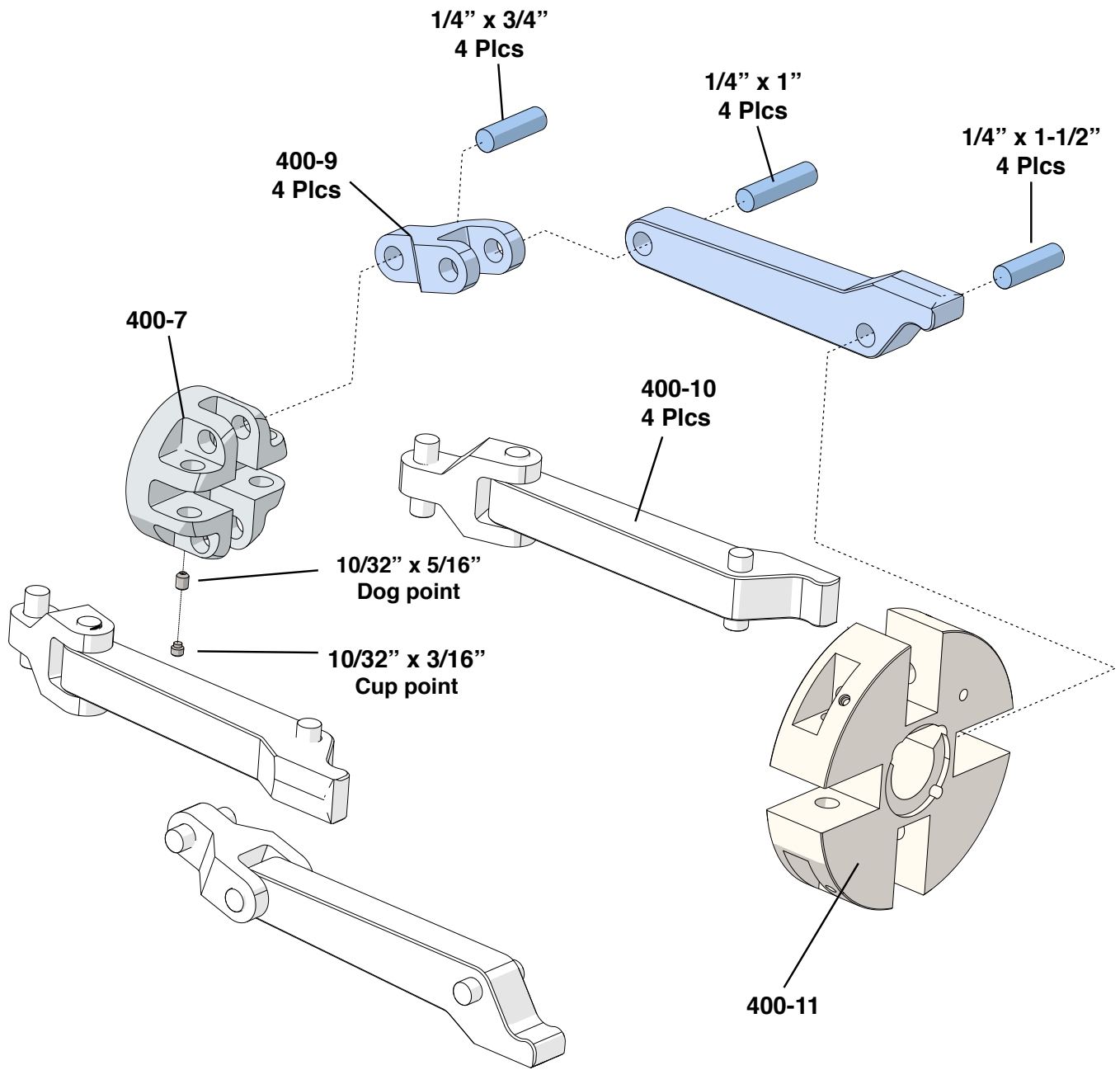

EC Assembly Illustration

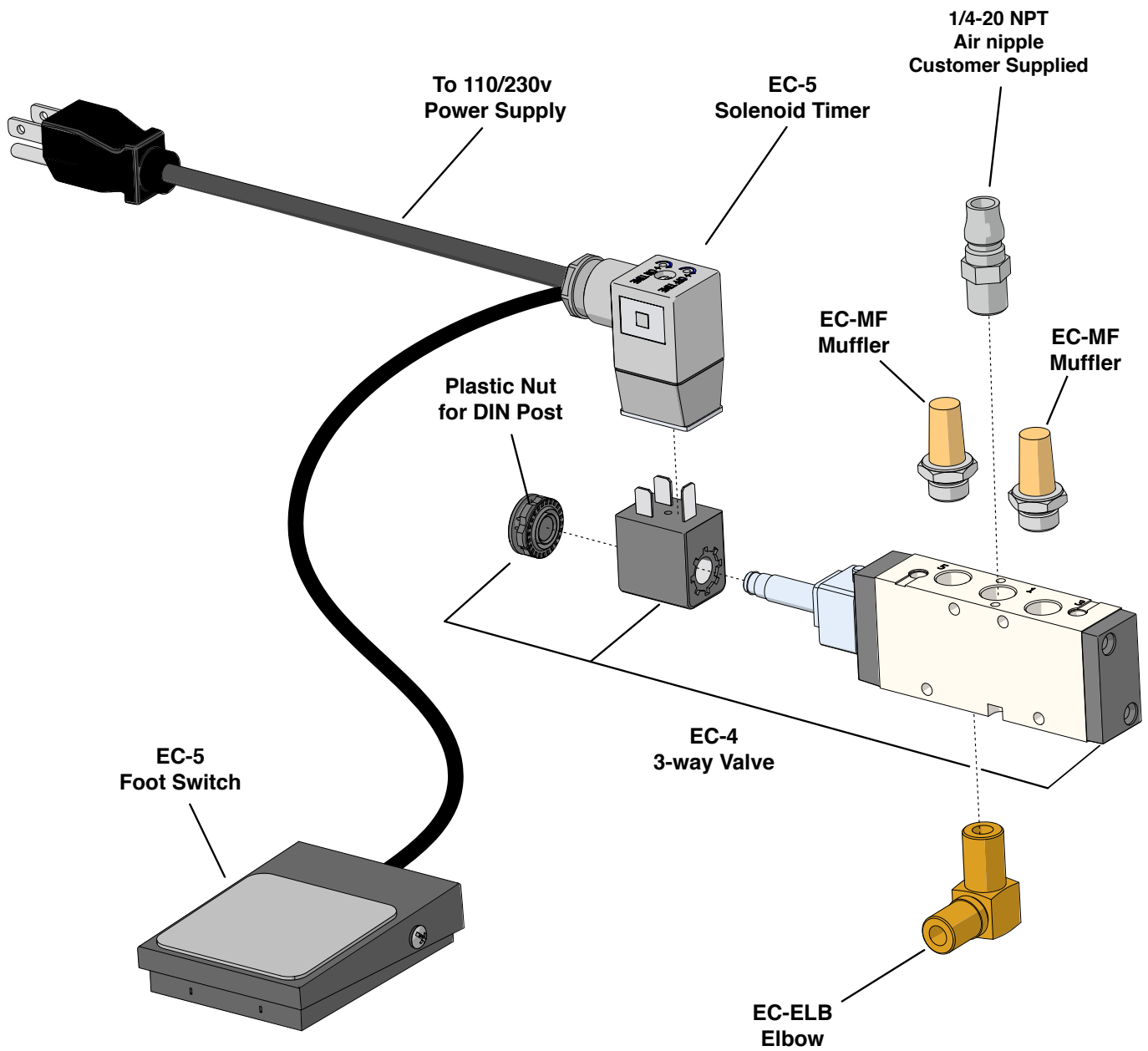

400 Crimping DIE

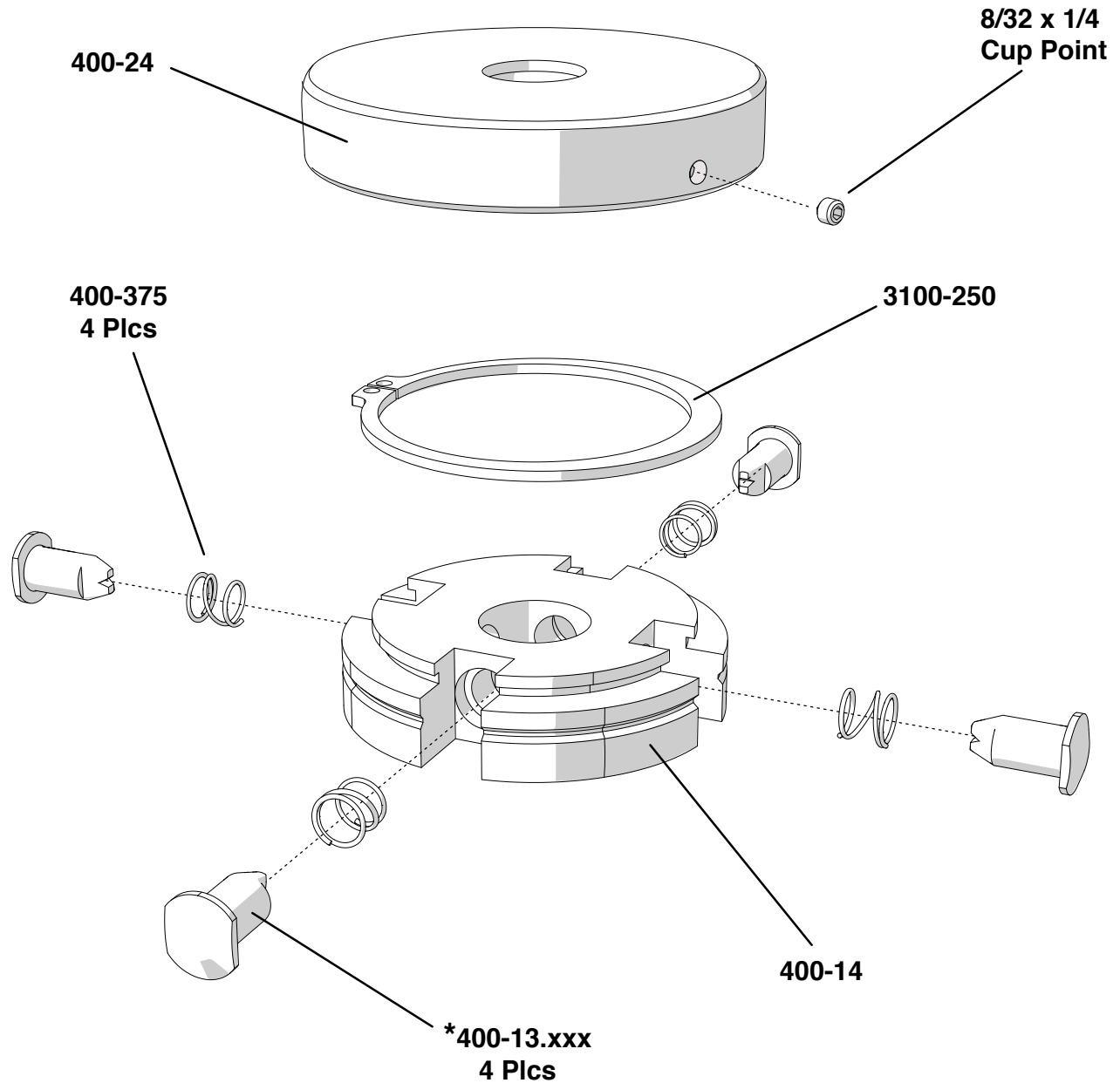

*** NOTE:** Die indentors are determined by application.
'xxx' refers to the die closure (proportional to crimp height).

Consult with Pico to determine the correct parts